



APE LEADS & SPOTTERS

DEEP FOUNDATION
SOLUTIONS



800-248-8498

WWW.AMERICANPILEDRIVING.COM



STANDARD BOX LEADS

Five sizes to fit all job and hammer requirements.

All tubing construction on 40 inch center for maximum strength with minimum weight.

Back rail, yokes and diagonal members are rectangular tubing.

Sections available in 10, 20, and 40 foot increments to suit any pile length.

All sections are precision made in production jigs to provide complete field interchangeability between old and new sections.

Alignment of sections is maintained by double clevis pin connectors. Sections connect with four high-strength steel pins for easy and fast set-up.

Each section is fitted with a full-length ladder. Ladder sides and rungs are spaced away from the leaders to provide maximum safety.

APE sells and rents a full line of standard pile hammers, leads and accessories to meet a wide variety of job requirement. Experienced APE personnel are available to insure that the proper components are provided to achieve the optimum arrangement for each job.



OPTIONAL AUGER GUIDE TRACK

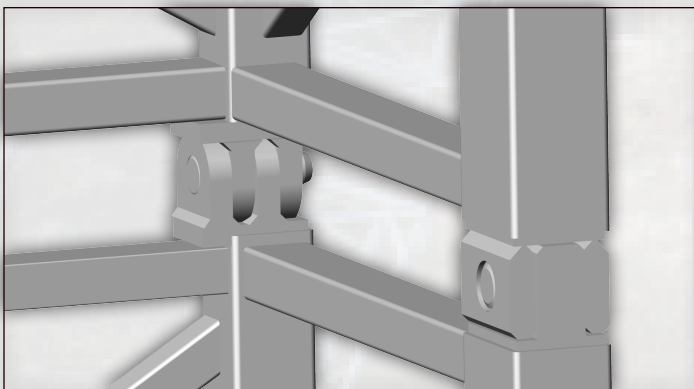

PIN CONNECTION

APE leads feature high strength pin connections. Pin connections are much stronger than bolted connections and are much faster to assemble and dis-assemble without requiring special tools. Assemble and dis-assemble without requiring special tools.

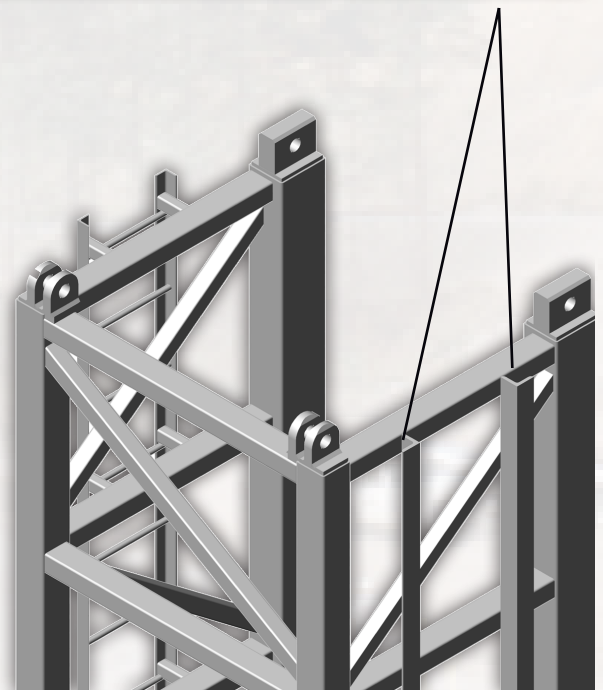

BOX LEAD WEIGHTS						
Sections (Length)	21"	26"	32"	37"	43"	54"
20' Tapered Top (Lbs)	2120	2140	2160	2280	2400	4720
4' Stabber (Lbs)	510	515	520	540	560	920
10' Intermediate (Lbs)	1400	1420	1450	1500	1550	2880
20' Intermediate (Lbs)	2700	2800	2840	2920	3040	5920
40' Intermediate (Lbs)	4800	5200	5400	5620	5850	10970
40' Intermediate-With Slide/Pin Rail (Lbs)	6600	7000	7200	7420	7650	12340
Headblock 4 Sheaves (Lbs)	1380	1400	1450	1500	1580	2550
Headblock 6 Sheaves (Lbs)	1500	1520	1580	1630	1700	2670
Boom Point Sled-Fixed (Lbs)	1160	1220	1340	1460	1580	1820
Boom Point Sled & Lifting Sheave (Lbs)	2090	2150	2270	2400	2520	2460
Lifting Sled, Winch And Sheave Assembly (Lbs)	2590	2630	2700	2780	2850	3860
Lifting Sled & Sheave Assembly (Lbs)	1580	1620	1690	1770	1830	2630
Spotter Sled-Fixed (Lbs)	750	800	870	940	1010	1420
Spotter Sled-Sliding Type (Lbs)	1090	1140	1210	1280	1350	1730

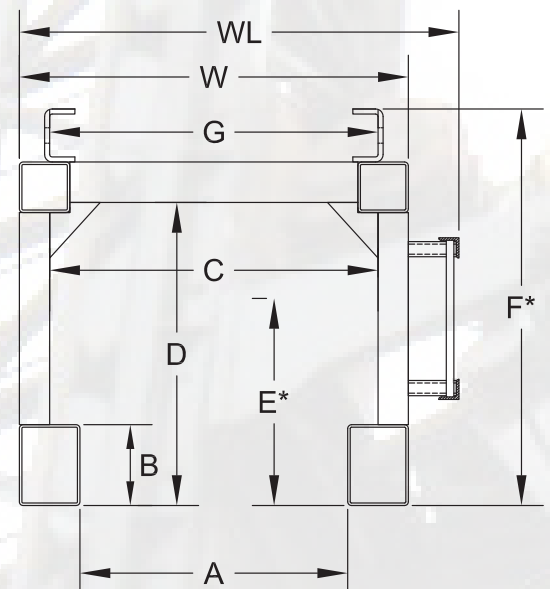

*DIMENSION WITH PIN-UP RAIL

BOX LEAD DIMENSIONS							
Key	8 x 21	8 x 26	8 x 32	8 x 37	8 x 43	10 x 54	10 x 64
A	21.50 in 54.61 cm	26.50 in 67.31 cm	32.50 in 82.55 cm	37.50 in 95.25 cm	43.50 in 110.5 cm	54.50 in 138.43 cm	64.50 in 163.83 cm
B	8.00 in 20.32 cm	8.00 in 20.32 cm	8.00 in 20.32 cm	8.00 in 20.32 cm	8.00 in 20.32 cm	10.00 in 25.4 cm	10.00 in 25.4 cm
C	27.50 in 69.85 cm	32.50 in 82.55 cm	38.50 in 97.79 cm	43.50 in 110.5 cm	49.50 in 125.73 cm	62.50 in 158.75 cm	72.50 in 184.15 cm
D	30.00 in 76.2 cm	30.00 in 76.2 cm	34.00 in 86.36 cm	42.00 in 106.68 cm	46.00 in 116.84 cm	48.00 in 121.92 cm	48.00 in 121.92 cm
E	15.29 in 38.84 cm	15.29 in 38.84 cm	16.94 in 43.03 cm	20.22 in 51.36 cm	21.87 in 55.55 cm	28.00 in 71.12 cm	28.00 in 71.12 cm
E*	22.10 in 56.13 cm	22.10 in 56.13 cm	24.50 in 62.23 cm	29.29 in 74.40 cm	31.69 in 80.49 cm	N/A	N/A
F	34.00 in 86.36 cm	34.00 in 86.36 cm	38.00 in 96.52 cm	46.00 in 116.84 cm	50.00 in 127 cm	54.00 in 137.16 cm	54.00 in 137.16 cm
F*	39.25 in 99.70 cm	39.25 in 99.70 cm	43.25 in 109.86 cm	51.25 in 130.18 cm	55.25 in 140.33 cm	N/A	N/A
G	27.50 in 69.85 cm	32.50 in 82.55 cm	38.50 in 97.79 cm	43.50 in 110.49 cm	49.50 in 125.73 cm	N/A	N/A
W	33.50 in 85.09 cm	38.50 in 97.79 cm	44.50 in 113.03 cm	49.50 in 125.73 cm	55.50 in 140.97 cm	74.50 in 189.23 cm	84.50 in 214.63 cm
WL	38.50 in 97.79 cm	43.50 in 110.5 cm	49.50 in 125.73 cm	54.50 in 138.43 cm	60.50 in 153.67 cm	79.50 in 201.93 cm	N/A
Weight	130 lb/ft (193.19 kg/m)	135 lb/ft (200.83 kg/m)	141 lb/ft (209.75 kg/m)	146 lb/ft (217.20 kg/m)	152 lb/ft (226.15 kg/m)	280 lb/ft (416.59 kg/m)	290 lb/ft (431.56 kg/m)



SWINGING LEADS

Swinging leads are hung from the crane boom by a crane line. The bottom of the leads are held in position by stabbing points. The crane line and boom are positioned to hold the line plumb or at the desired batter.

Swinging leads are the lightest, simplest, and least expensive. Precise alignment of the crane and pile is not required. It is possible to drive in a hole or over the edge of an excavation. However, swinging leads requires three crane lines (lead, hammer & pile). Precise positioning of the leads is slow and difficult.



SWINGING LEADS COMPONENTS

APE swinging leads are assembled from four basic components -- a 20-foot top section, a 20-foot bottom section, and 10 and 20-foot intermediate sections. A 4-foot stabber fits on the bottom. The 20-foot tapered top section is used at the top of swinging.

leads. The taper at the back of the leads provides the required clearance for the crane boom. A bail attachment is a standard part of the tapered top section and it accepts a standard shackle. The top section has a full-length ladder (except for the top eight feet). Multiple 10 and 20-foot intermediate sections are used to provide various lengths of leads. Intermediate leads sections have full length ladders.



20' TAPERED TOP

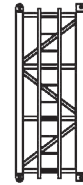

10' INTERMEDIATE



20' INTERMEDIATE



20' INTERMEDIATE



4' STABBER

FIXED EXTENDED LEADS

Fixed, extended leads extend above the boom-point. They are connected to the boom-point with a swivel connection to allow movement in the fore-aft and side-to-side directions. A spotter connects the bottom of the leads to the front of the crane. A headblock directs the crane lines over the top of the leads. A rooster sheave at the boom-point guides the line to the headblock.

Extended leads require only a two-line crane (pile & hammer) although a third auxiliary line may be used if desired. Excellent speed, control, and accuracy is possible in positioning the leads. Side-to-side as well as fore and aft adjustment is possible. A shorter boom may be used. However, extended leads are more expensive and require more time to setup.



FIXED EXTENDED COMPONENTS

APE fixed, extended leads are assembled from seven components-10, 20, and 40 foot intermediate sections, a headblock, a boom-point connector, a rooster sheave and a spotter.

The 40-foot section has a slide rail track to allow vertical positioning of the boom point connector. Multiple 10 and 20-foot intermediate sections may be used both above and below the 40-foot section to allow complete flexibility in boom and lead lengths.

The boom point connector slides in the rail track located on the back of the 40-foot lead section and can be pinned off the connection point. The connector permits full fore-aft and side-to-side movement.

The headblock, which carries lines over the top of the leads, is available with either 4 or 6 sheaves to handle either 2 or 3 lines.

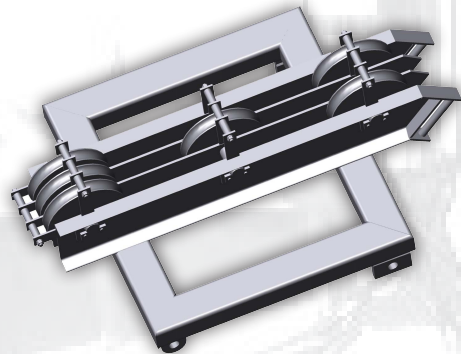

The rooster sheave has 3 sheaves to handle either 2 or 3 lines.

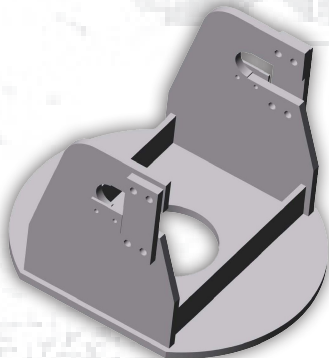
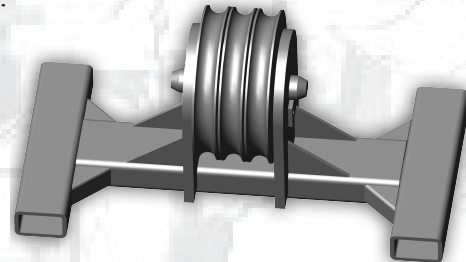

The APE Model spotters (see back of brochure) may be used to position the bottom of the leads.

Custom boom point connectors can be fabricated to fit Manitowoc, American, P & H, Link Belt or any other model crane boom tip. Consult the factory for more information concerning custom application for your equipment or situation. 1-800-248-8498.

SLIDING EXTENDED LEADS

Sliding, extended leads have all of the features of fixed, extended leads. In addition, sliding leads may be raised or lowered vertically approximately 40 feet independent of the boom position. Also, the leads may be rotated 45 degrees each way about their longitudinal axis. The added features provides a number of operating advantages:

- Allows leads to be raised or lowered in any batter position.
- Allows driving of longer piles by raising leads at start of driving, and later lowering to cut-off elevation.
- Allows the hammer to be guided to cut-off elevation regardless of boom position.
- Allows leads to be lifted clear of any obstruction.
- Allows crane to sit on ground higher than pile area without leads interfering with ground.
- Allows leads to be supported on the ground where desired for long reaches or extra-heavy piles or hammers.
- Allows pile hammer to be mounted by first raising and then lowering the leads into the hammer guides, eliminating the need to use a hole in the ground or to unbolt the hammer guides.

Sliding, extended leads can be raised or lowered using a standard crane drum if the crane is so equipped. If the crane does not have a third drum, APE can mount a third winch onto the lower end of the 40-foot sliding lead section or any part of the leads below the bottom tip.

SLIDING EXTENDED COMPONENTS

The components which make up APE sliding, extended leads are shown above.

A 40-foot sliding section accepts the sliding boom-point connector box to provide full vertical movement of the leads at the boom-point. A second 20-foot sliding section accepts the spotter sliding box to permit the spotter to be positioned within a 14-foot vertical range at the bottom of the leads. Multiple 10 and 20 foot intermediate sections may be used in conjunction with the 40 foot sliding sections to permit the use of various lead and boom lengths.

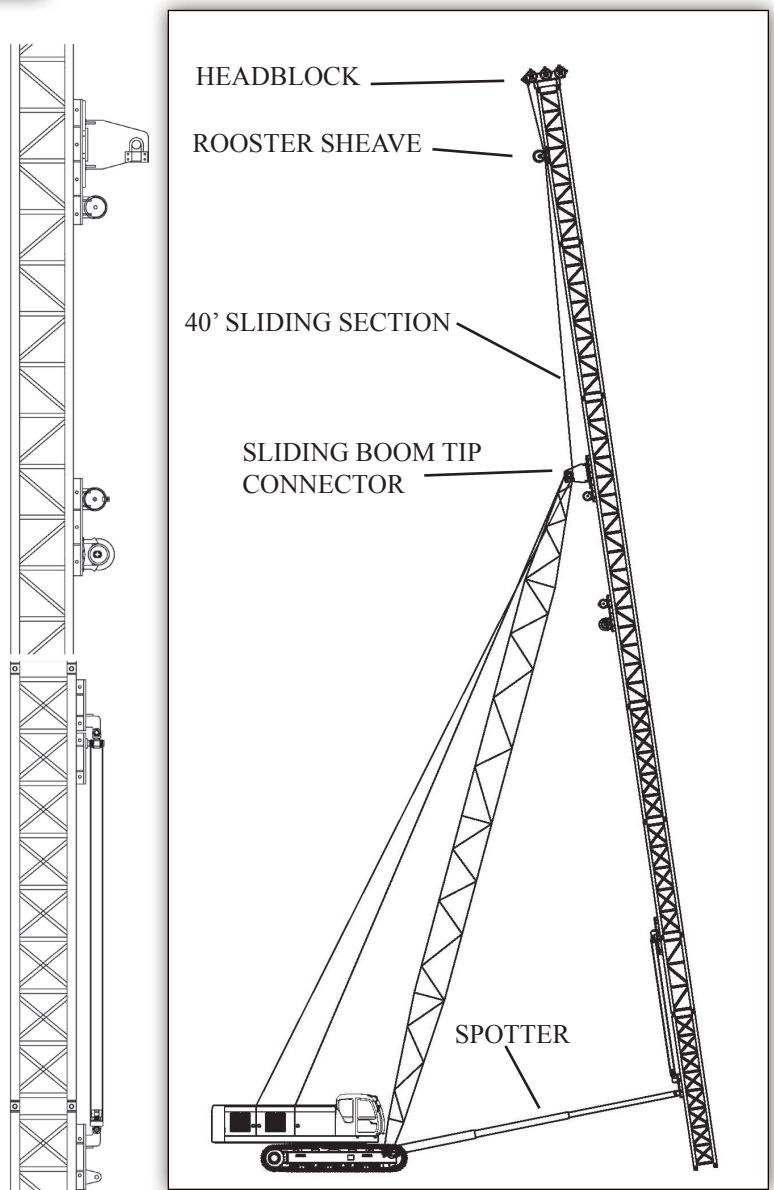

The boom-point connector which connects the crane boom to the boom-point connector box allows movement in six directions-fore & aft, side-to-side and leads rotation each way. Rotation is controlled at spotter.

Optionally, the rooster sheave can swivel in all directions to allow for the six-way movement of the leads at the boom point.

The spotter connects the leads to allow six-way movement at the bottom of the leads. Six-way movement is optional.

The headblock, which carries the crane lines over the top of the leads, is available with either 4 or 6 sheaves to handle either 2 or 3 lines and can be equipped with sheaves on the side for auger work.

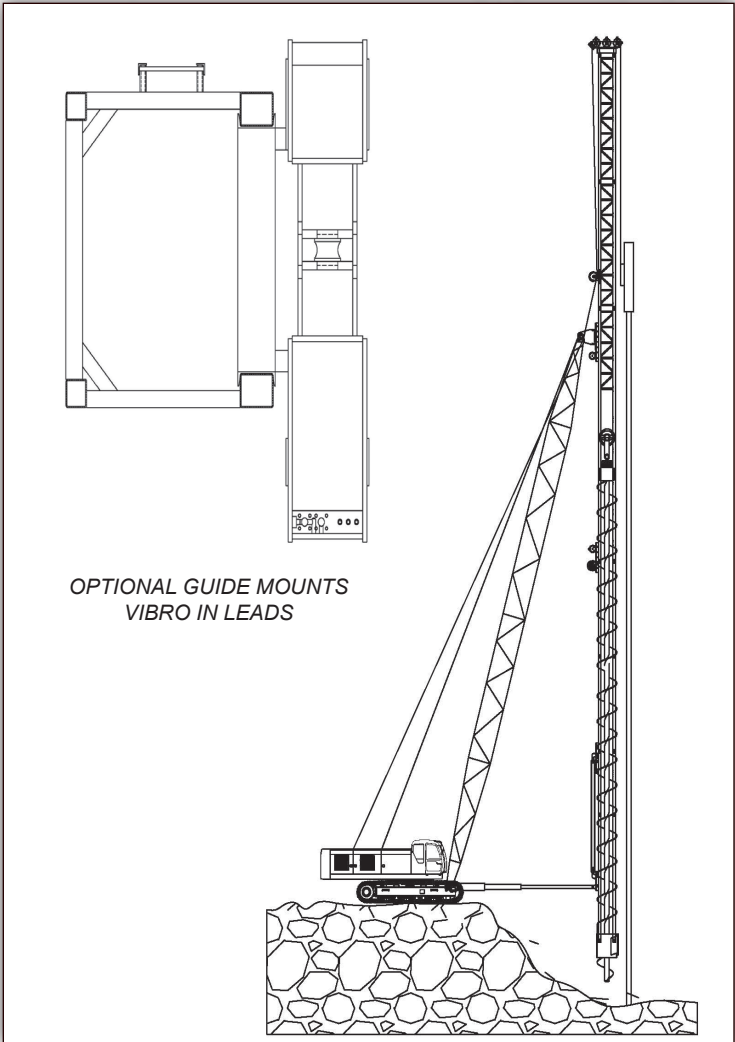

VIBRO WITH H-BEAM IN FRONT AND DRILL MOUNTED ON SIDE

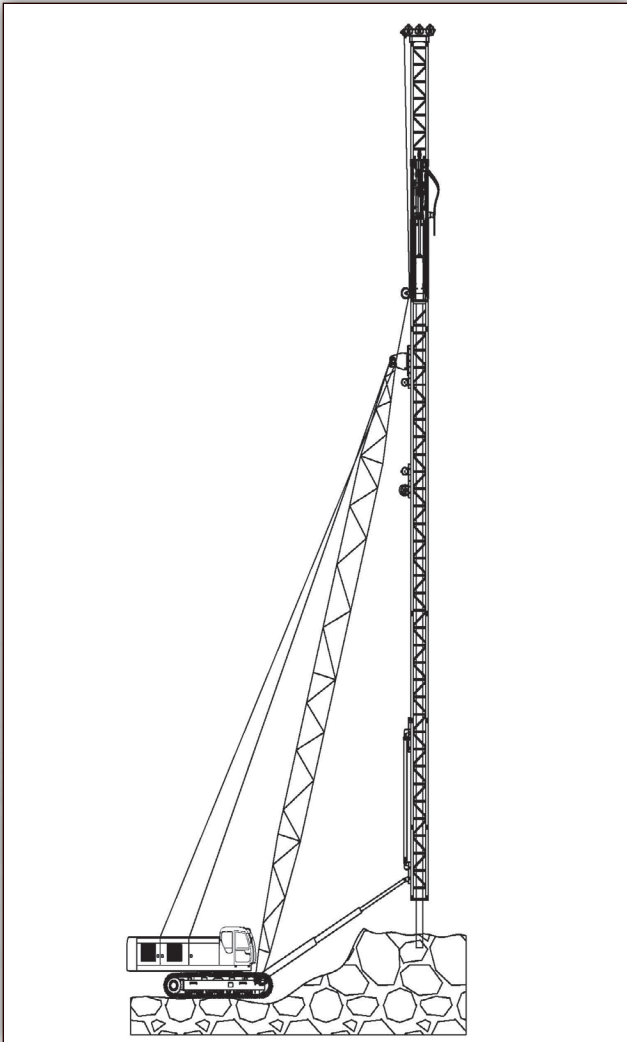

APE HYD. IMPACT HAMMER DRIVING 24" SQUARE CONCRETE

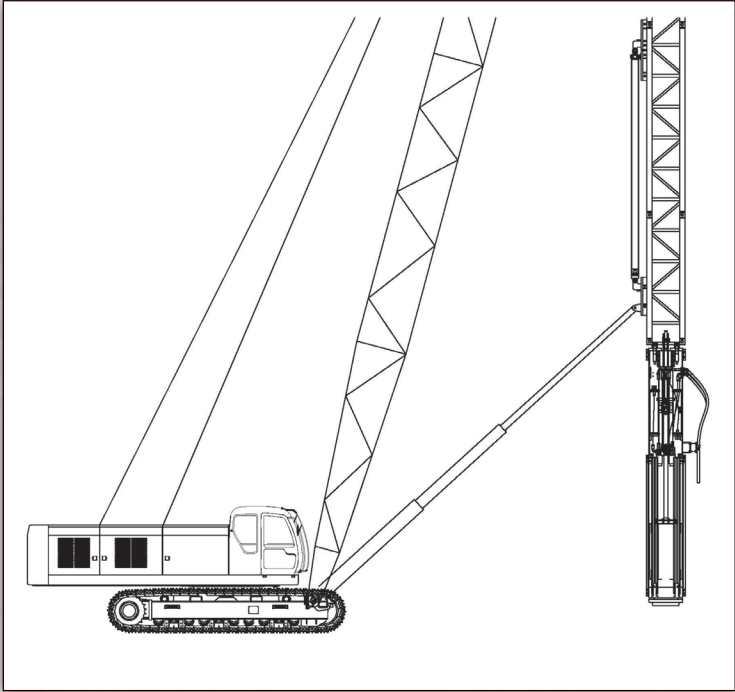

LEADS CAN BE INSTANTLY RAISED FOR EASY HAMMER MOUNTING

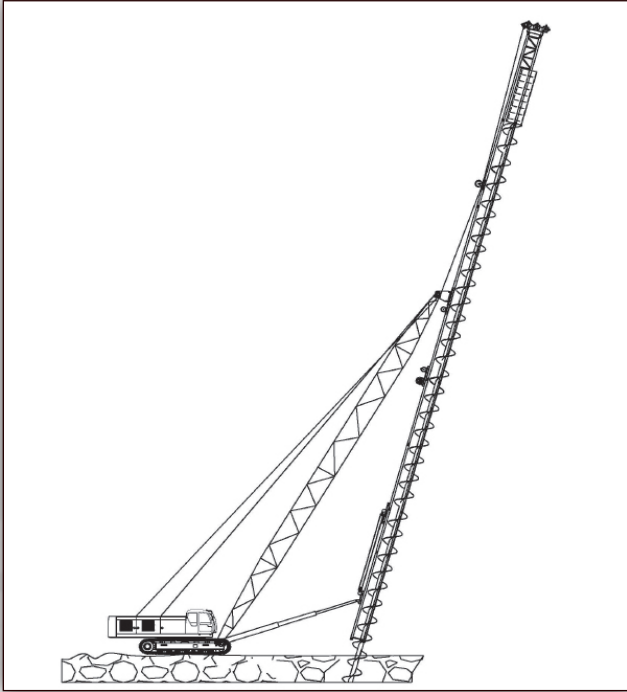

AUGERED CAST-IN-PLACE PILES OR PILE PRE-DRILLING WORK

FRONT RIDING EUROPEAN STYLE LEADS

FRONT RIDING LEAD WEIGHT SPECIFICATIONS

Sections	ST-75 STD	ST-75 FIXED	ST-100 STD	ST-100 FIXED	ST-150 STD	ST-150 FIXED	ST-190 STD	ST-190 FIXED
10' Tapered Top (Lbs)	800	---	1100	---	1650	---	2100	---
4' Stabber (Lbs)	400	400	500	500	600	600	720	720
10' Intermediate (Lbs)	900	1250	1200	1550	1750	2100	2200	2550
20' Intermediate (Lbs)	1650	2350	2200	2900	3250	3950	4100	4800
40' Intermediate (Lbs)	3150	4550	4200	5600	6250	7650	7900	9800
Headblock 4 Shaeaves (Lbs)	---	1300	---	1400	---	1500	---	1600
Headblock 6 Sheaves (Lbs)	---	1420	---	1520	---	1620	---	1720

FRONT RIDING LEADS ST-75 STANDARD

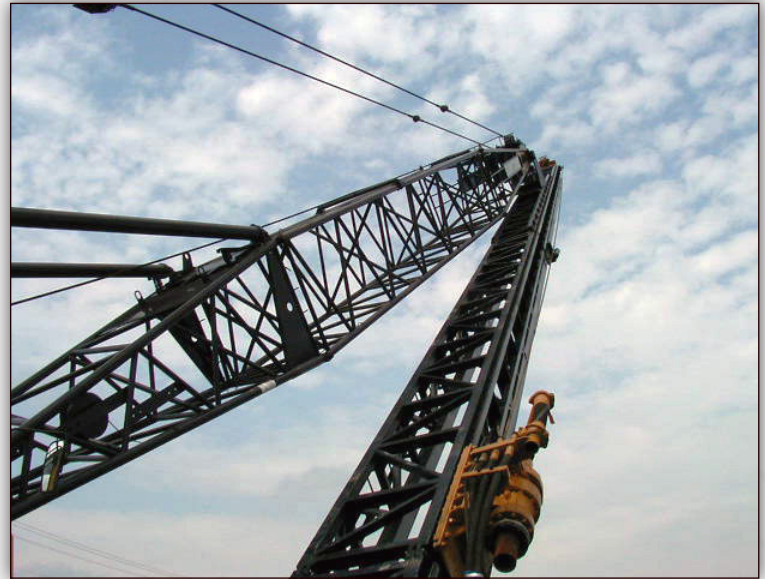
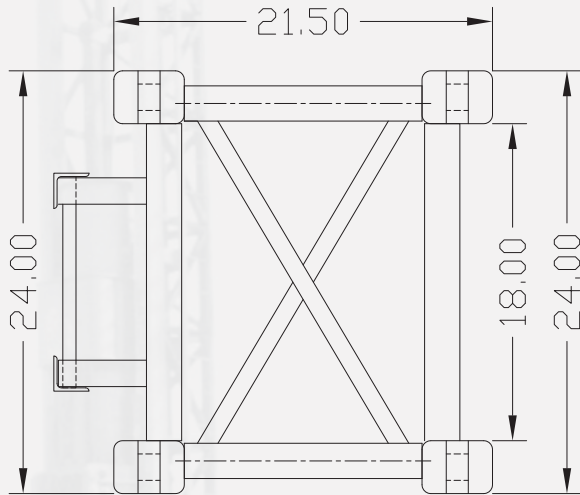

FRONT RIDING LEADS ST-75 FIXED

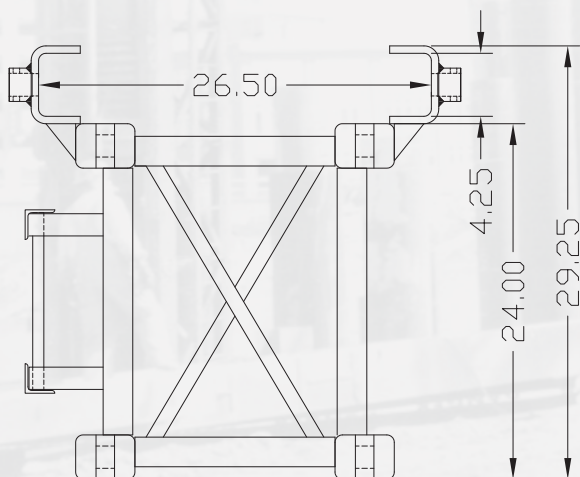

FRONT RIDING LEADS ST-100 STANDARD

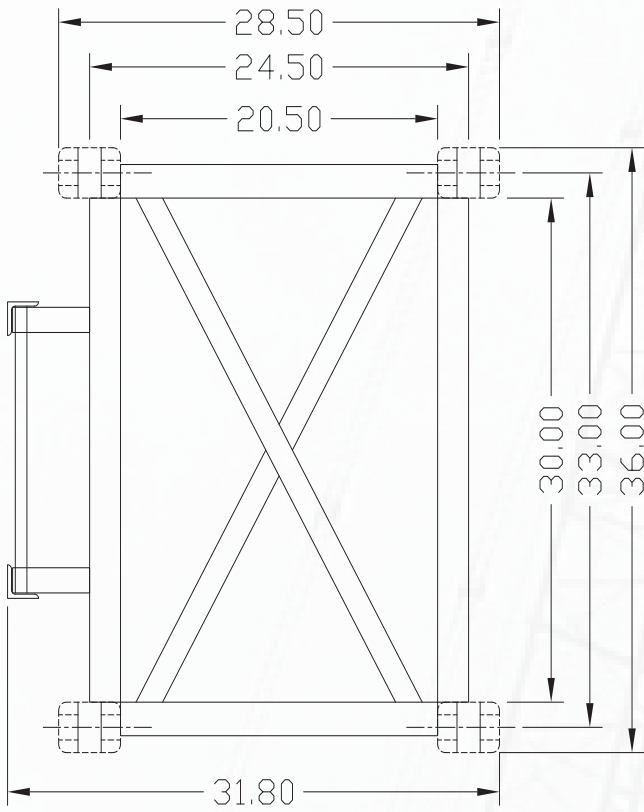

FRONT RIDING LEADS ST-100 FIXED

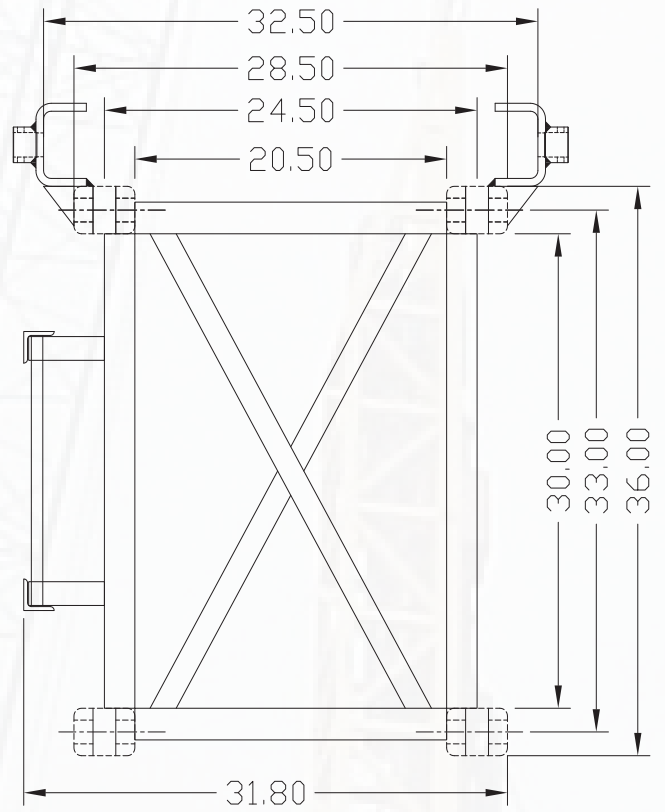

FRONT RIDING LEADS ST-150 STANDARD

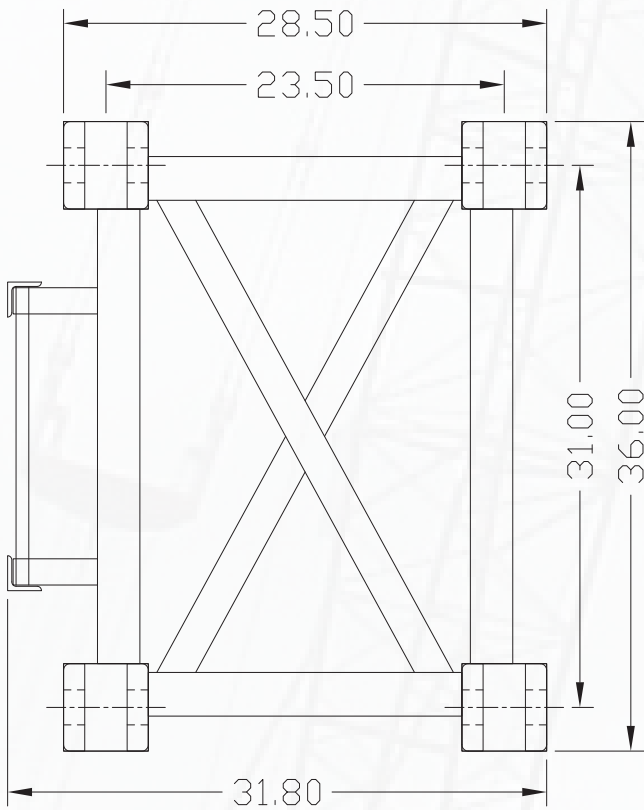

FRONT RIDING LEADS ST-150 FIXED

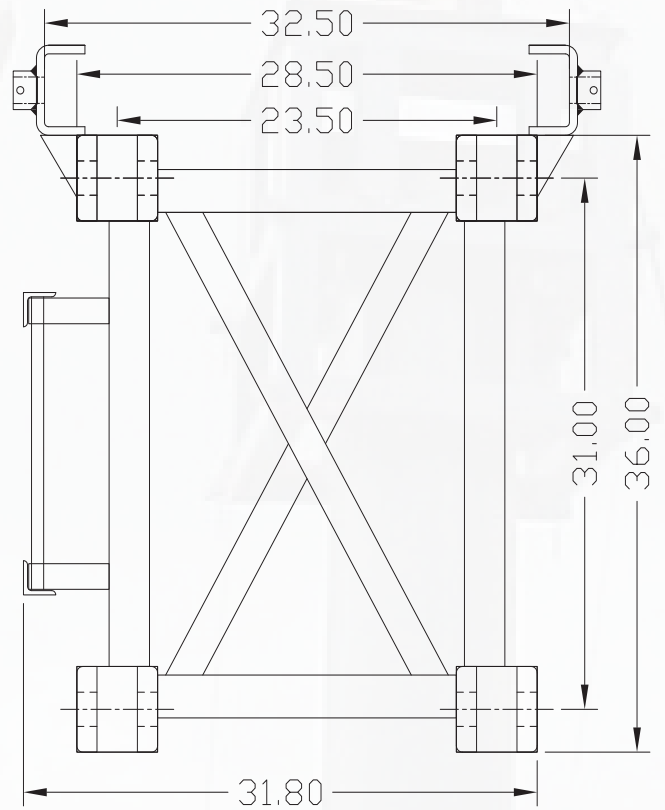

FRONT RIDING LEADS ST-190 STANDARD

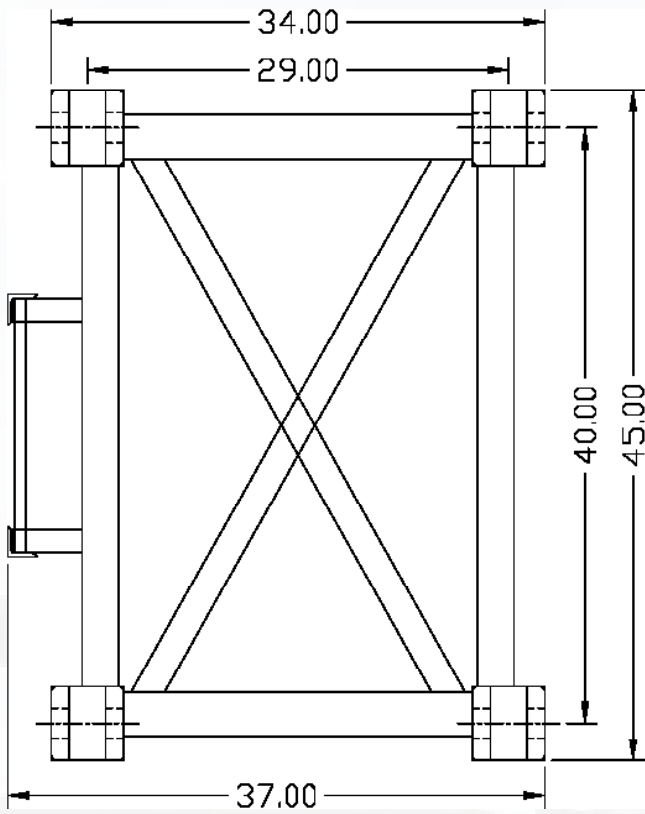

FRONT RIDING LEADS ST-190 FIXED

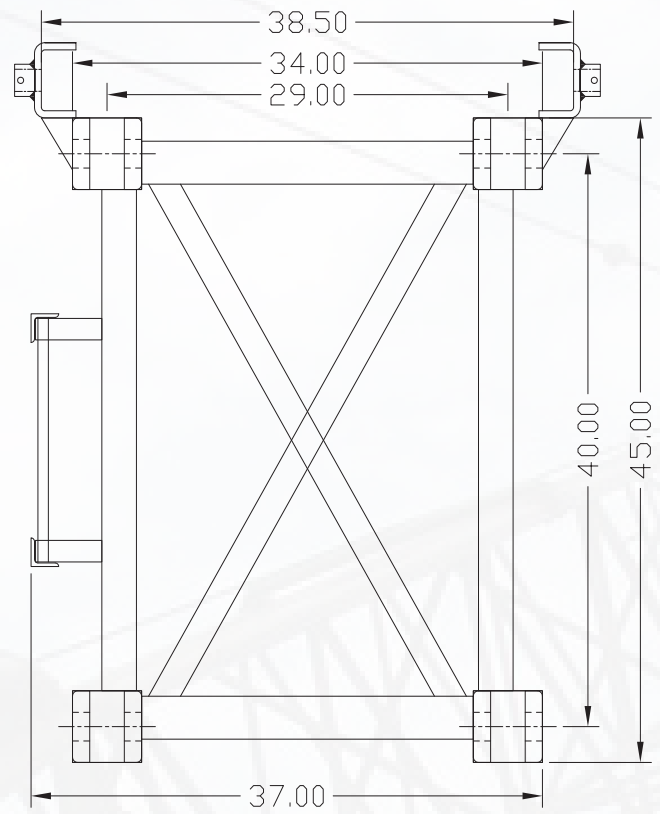

PILE GATE

Swinging pin-on pile gate for aple series leads

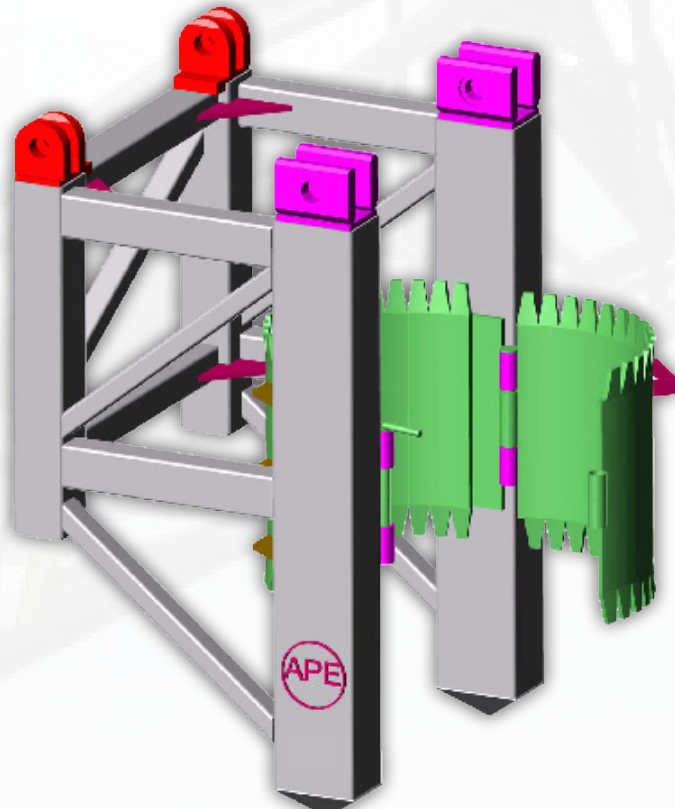

PIPE GATE

Hydraulic pipe gate for aple Series leads

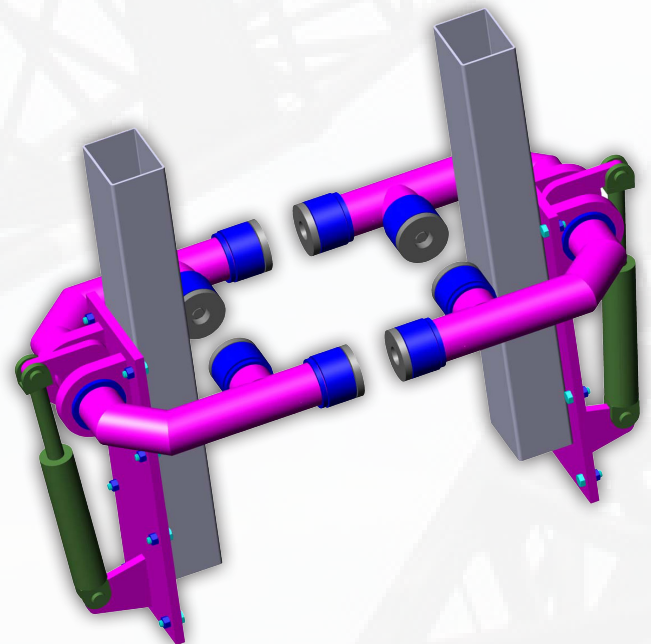

OFF SHORE LEADS

Adjustable diameter off shore leads for impacting large piles

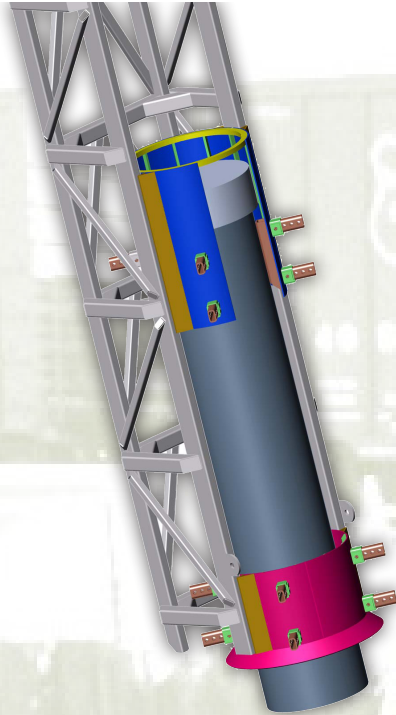

BOTTOM DRIVE ASSEMBLY

Direct drive bottom drive assembly for impacting large diameter piles

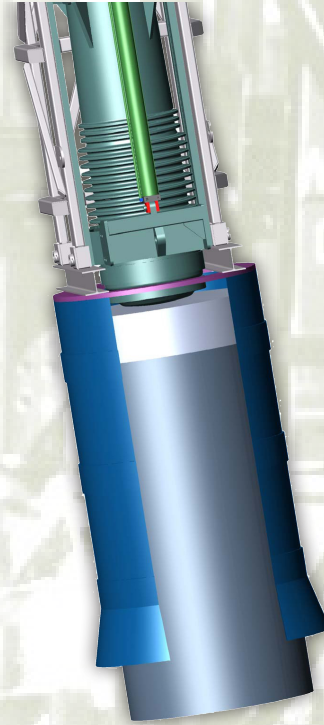

SPOTTERS

SPOTTER SPECIFICATIONS

Specifications	Units	100B	150B	368
Hydraulic Extension	Ft.	10	20	30
Manual Extension	Ft.	10	0	0
Extended Force	Lb.	18,000	28,000	60,000
Retract Force	Lb.	19,000	32,000	62,000
Retracted Length	Ft.	17	17	26
L/R Travel Extended	Ft.	6	35	52
L/R Force Extended	Lb.	7,200	12,000	28,000
L/R Travel Retracted	Ft.	6	15	23
L/R Force Retracted	Lb.	7,200	25,900	61,000
Maximum Width	Ft.	8	8	10
Maximum Pressure	PSI	1,500	2,500	2,500
Weight	Lb.	7,000	8,500	31,100
Power Lead Rotator	N/A	Option	Option	Option

- Vibratory piledriver/extractors
- Hydraulic impact hammers
- Augers for augured cast-in-place piles
- Drills for caisson work
- Wick drain installation equipment
- Mini-vibros for backholes
- Pile leads and spotters
- Super vibro for giant caisson work
- Specialized in equipment operating on
- Non-toxic vegetable hydraulic oils

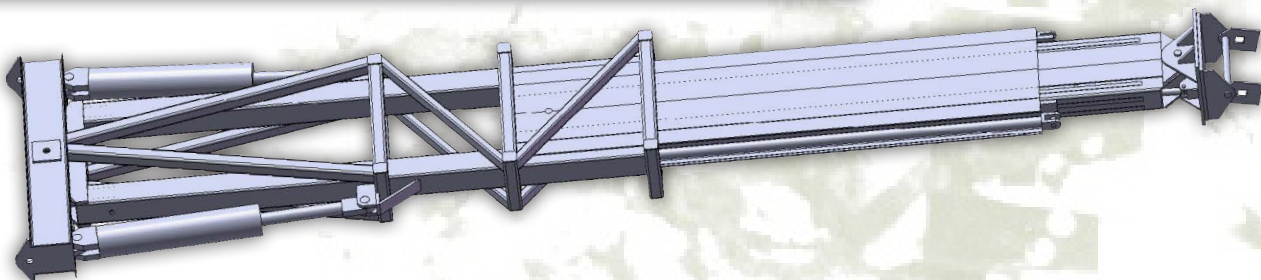

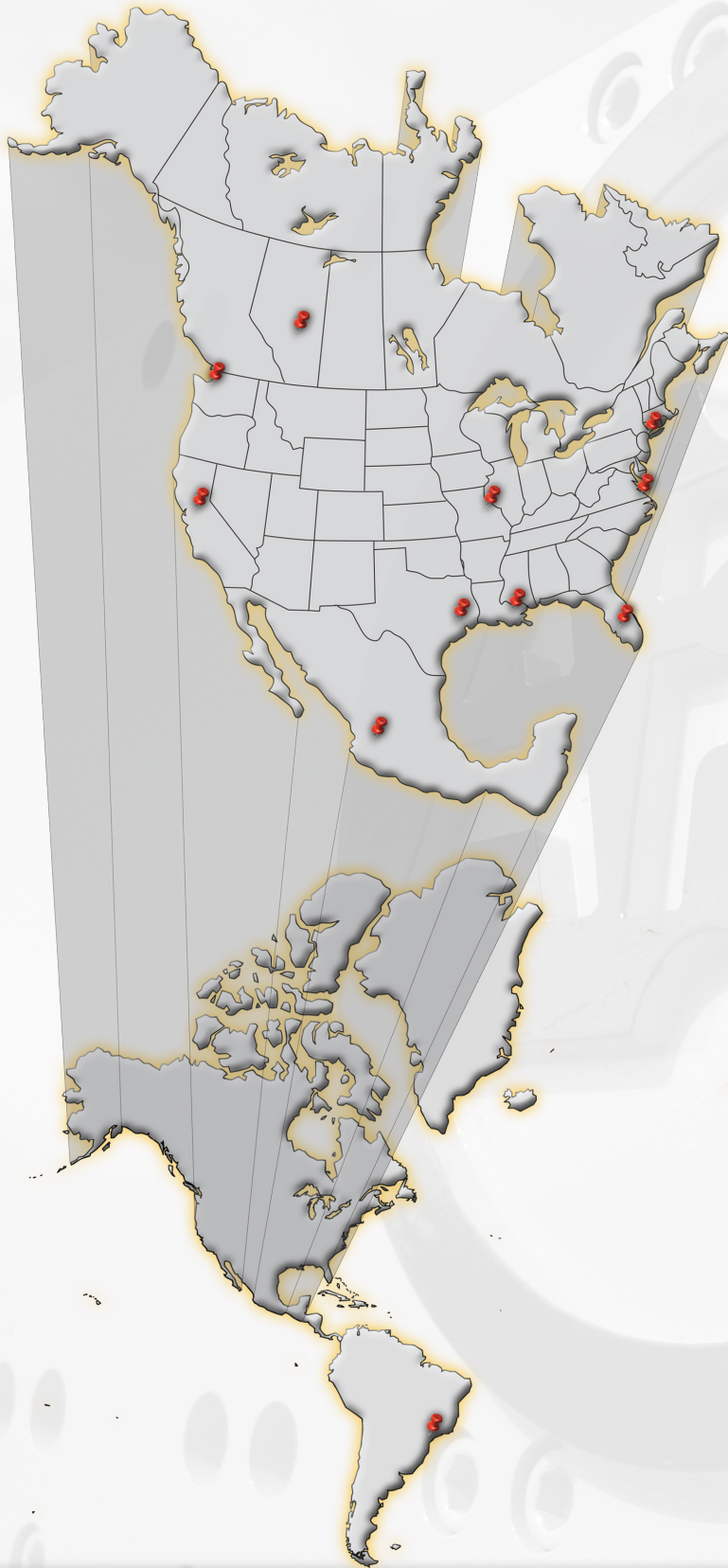

BRANCH LOCATIONS

NORTHWEST | CORPORATE

7032 South 196th St.
 Kent, WA 98032
 Ph: (253) 872-0141
 Fx: (253) 872-8710
 (800) 248-8498
 stevec@americanpiledriving.com
 kellyg@americanpiledriving.com

WEST COAST

2985 Loomis Rd.
 Stockton, CA 95205
 Ph: (209) 942-2166
 Fx: (209) 942-2455
 (888) 245-4401
 chrisc@americanpiledriving.com

CANADA

1002 7th Street
 Nisku, Alberta T9E 7P2
 Ph: (780) 474-9888
 (855) 328-9888
 ericl@americanpiledriving.com

GULF REGION

3975 FM Hwy 1485
 Conroe, TX 77306
 39266 Doyle Dr., Ste. A
 Gonzales, LA 70737
 Ph: (936) 271-1044
 Fx: (936) 271-1046
 (800) 596-2877
 joew@americanpiledriving.com

MEXICO & CENTRAL

Avenida Periferico Sur 7800
 Sta. Ma Tequetexpan
 Tlaquepaque, Guadalajara Jalisco
 Mexico CP. 45601
 Ph: (253) 368-3911
 Fx: (253) 872-8710
 +1 (877) 457-5022
 davidm@americanpiledriving.com

NORTHEAST

401 Hartle St.
 Sayreville, NJ 08872
 Ph: (732) 432-6604
 Fx: (732) 432-6608
 (888) 217-7524
 billz@americanpiledriving.com
 paulk@americanpiledriving.com

CHINA

Building No. 258 Yang Nan Road
 Baoshan District
 Shanghai, China 201906
 Ph: +86-13601889007
 Ph: 011-86-21-5677-1221
 Fx: 011-86-21-3604-0553
 ericd@apevibro.com

MID-WEST

50 Gerber Industrial Dr.
 St. Peters, MO 63376
 Ph: (636) 397-8400
 Fx: (636) 278-4278
 (877) 296-8044
 Loganh@americanpiledriving.com

PILING PRODUCTS

24430 FM 1488, Ste. A
 Magnolia, TX 73355
 Ph: (936) 372-9760
 mattf@apedrilling.com

MID-ATLANTIC

500 Newtown Rd., #200
 Virginia Beach, VA 23462
 Ph: (757) 518-9740
 Fx: (757) 518-9741
 (866) 399-7500
 jimmyd@americanpiledriving.com

SOUTHEAST

1345 Industrial Park Rd.
 Mulberry, FL 33860
 Ph: (863) 324-0378
 Fx: (863) 318-9409
 (800) 570-3844
 jimb@americanpiledriving.com
 jimc@americanpiledriving.com
 wallyb@americanpiledriving.com

The APE product line is protected by, but not limited to the following patent numbers:
 5088565A, 5117925A, 5263544A, 5529132A, 5544979A, 5609380A, 5653556A,
 5794716A, 6039508A, 6386295B1, 6427402B1, 6431795B2, 6447036B1, 6543966B2,
 6648556B1, 6672805B1, 6732483B1, 6736218B1, 6896448B1, 6908262B1, 6942430B1,
 6988564B2, 7168890B1, 7392855B1, 7694747B1, 7708499B1, 7824132B1, 7854871B1,
 7913771B2, 7950876B2, 7950877B2, 8070391B2, 8181713B2, 8186452B1, 8434969B2,
 8496072B2, 20090200055A1. For a more detailed information and a more comprehensive
 list of APE patents please visit the website at www.apevibro.com/ver2/APEpatents.asp.

800-248-8498
WWW.AMERICANPILEDIVING.COM

